

Streamline®

Compounding Isolator

**Compounding Aseptic Containment Isolators
(Recirculating and Total Exhaust)**

The Premium Solution for Aseptic Drug Compounding



STREAMLINE® COMPOUNDING ISOLATOR

Streamline® Compounding Isolator (SCI) provides an aseptic environment for pharmaceutical preparations. SCI provides an aseptic environment for pharmaceutical preparations. It can be configured to operate in a recirculating or total exhaust air flow scheme.

Also, aside from positive pressure, this particular unit has two negative pressurization classifications, the purposes of which are:

- N1: factory-configured to provide a more negative pressured pass-through-chamber (PTC) in accordance with the CETA guideline for testing compounding isolators.
- N2: this unit is intended for powder handling applications, thus, the work chamber (- 37Pa) is more negative than the PTC (- 25Pa).

Overall, the SCI is designed to provide user, product, environment, and cross-contamination protection from exposure to hazards.

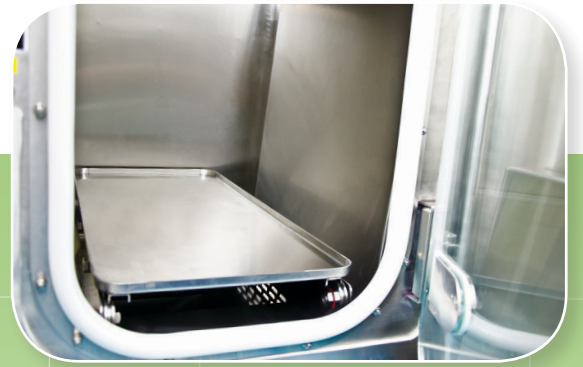

2



SCI Stainless Steel Recirculating Unit



Applications

Potent Formulations

Aseptic Compounding

Chemotherapy

TPN Formulation

Contained Powder Handling

Cell Culture

Gene and Cell Therapy

Tissue Engineering

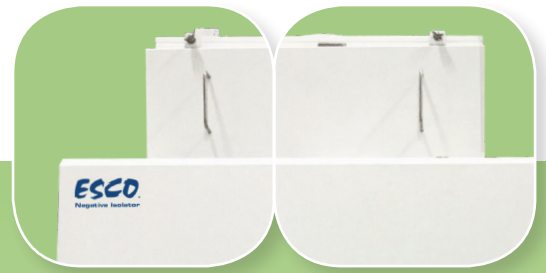

Main Features

- Designed in compliance to international cGMP standards.
- Class 3 Leak Tight Containment, as per ISO 10648-2.



SCI Electrogalvanized Steel Recirculating Unit



SCI Electrogalvanized Steel Total Exhaust Unit

Safety and Certification

	Design	Cabinet Performance	Air Cleanliness	Electrical Safety
Standard Compliance	USP <797> and <800>, USA NIOSH, OSHA, Designed in compliance to international GMP standards	ISO Class III Leak Tight Containment as per ISO 10648-2, CETA CAG-002-2006	ISO 14644-1 Class 3 (at rest), Class 5 (in operation), EU GMP Grade A, Worldwide JIS B9920, Class 3, Japan BS 5295, Class 1, UK	IEC 61010-1, Worldwide EN 61010-1, Europe UL 61010-1, USA CAN/CSA-22.2, No. 61010-1



SCI Total Exhaust Unit



Main Features

- ULPA filters (as per IEST-RP-CC001.3 and HEPA (H14) filter as per EN 1822) with a typical efficiency of >99.999% at 0.1 to 0.3 microns, providing ISO Class 5 air cleanliness as per ISO 14644-1.
- Bag-In Bag-Out (BIBO) Exhaust Filter at the top allows for safe and convenient filter change.
- Sentinel™ Gold Microprocessor controller supervises all functions and monitors airflow and pressure in real-time.
- For negative pressure configuration, the work zone and pass-through interchange are under negative pressure to the room to maintain operator protection in the event of a breach in the isolation system.
- For positive pressure configuration, both the work zone and pass-through chambers are under positive pressure to the room to ensure product protection.
- Robust dual-wall construction. Unique Escro Dynamic Chamber™ plenum surrounds filter seals with negative pressure.
- Ergonomically angled front to improve reach and operator comfort.
- Adaptor plate for utilities/accessories (BioVap™/Sharps bin)
- Safe-change cuff rings permit glove changes with zero risk of contaminating the work zone or environment.
 - Sleeves are made of Hypalon material while gloves are determined by user requirements.
- The unit has FDA-grade air-tight seals.
- It has easy to clean work zone without any crevices.
- Options for external material of construction:
 - Electrogalvanized steel with ISOCIDE™ antimicrobial powder coating
 - Full stainless steel 304
- It has options to have a sharps disposal system:
 - bottom of the work zone
 - inside the work zone
 - beside the work zone*
- A hydraulic height-adjustable stand is available as an option.
- The unit is equipped with Foot Switch to open the inner doors.



SCI Recirculating Unit



*Sharps bin for these units (recirculating) can have a negative pressured enclosure.

Options and Accessories



The **United States Pharmacopeia (USP)** General Chapters <797> and <800> together with the FDA 503B Guidance, states the need for proper **documentation** of the standard operating procedures (SOPs) surrounding the activities for sterile pharmaceutical preparations.

- Utilizes energy-efficient light-emitting diode (LED) which has higher durability and better lighting quality.
- Connections for particle count probe and viable monitoring.
- Internal chamber of SCI consists of two (2) planes made from single-piece SS 316L with 19 mm radius coved corners.
- Work top with a drain pan at the bottom.
- Electromagnetic interlocking door with time-delayed ingress/egress control to minimize particle entry; assuring work zone sterility during material transfer.
- Unit's external exhaust fan has zero volt relay interlock.

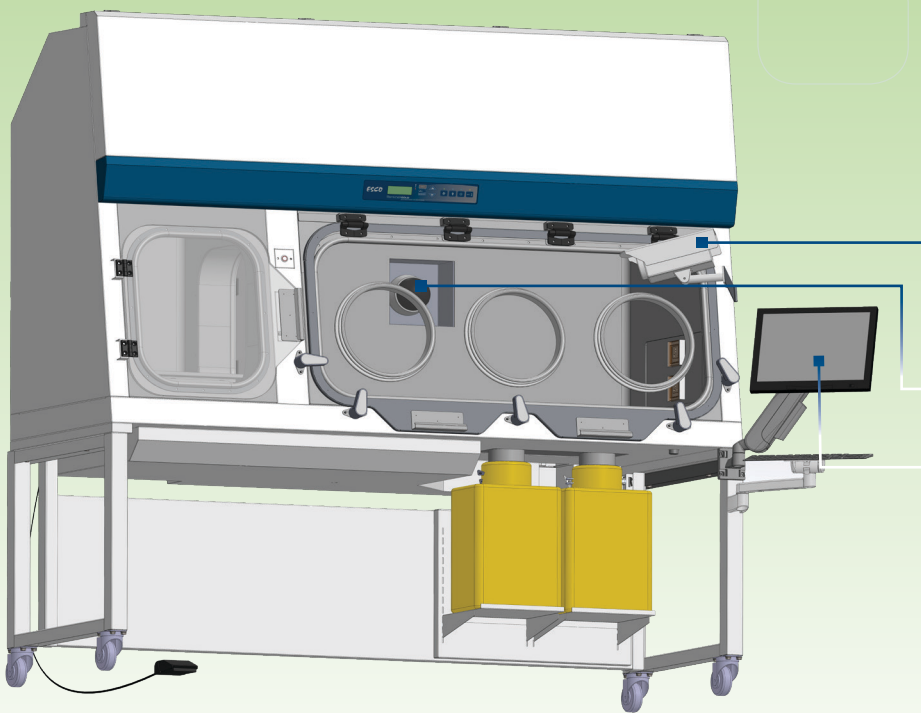

Esco's integration options for a **CCTV** and a **monitor** and **keyboard mount** can easily provide real-time monitoring and recording of personnel activities; meeting the demands of international guidelines.

CCTV integration:

- front panel with a stainless steel mount
- rear wall of the work zone

Monitor and Keyboard integration:

- access to rear view monitor system
- beside the front panel equipped with a keyboard and mouse arm



Mobile BioVap™ Biodecontamination System capable of achieving a 6 log reduction in bioburden. This is usually integrated through the adaptor plate at the right-most part of the isolator's inner work zone.

Note: This adaptor plate can be used to house either the sharps bin (SE design), the mobile BioVap™ nozzle, or other retrofitted utilities/accessories.



Adjustable foot rest



Stainless steel turntable



Flexible ducting work



Laboratory cart



Butterfly Valve:

- Manual
- Automatic

AIRFLOW PATTERNS FOR STREAMLINE® COMPOUNDING ISOLATOR MODELS

Recirculating Airflow

- Ambient air is pulled through the inlet pre-filter and main filter located on top of the isolator.
- The downflow filter creates a laminar air flow providing ISO Class 5 air cleanliness (ISO 14644-1) to the main chamber and pass-through, with a down flow velocity of 0.40 m/s +/- 20%.
- Air from the work zone and pass-through is quickly purged out by the exhaust fan to keep the area clean. The fan pulls approximately 90% of the purged air back to the plenum, passes through the HEPA downflow filter again, and is recirculated back to the work zone and pass-through.
- Approximately 10% of the purged air is exhausted through the filter to prevent heat build-up inside the isolator.
- Exhausted air is replenished by ambient air coming from the top inlet pre-filter that has 80% efficiency.

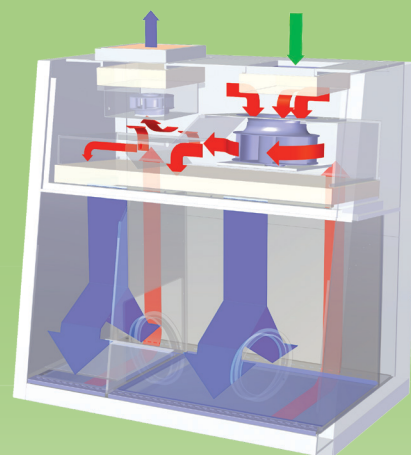

- HEPA-filtered air
- Room air / Ambient air
- Unfiltered / Potentially contaminated air

Guide to Streamline® Compounding Isolator Models

SCI-3GC8-N

Isolator Unit	Model	No. of gloves - Nominal Width		Glove port design	Voltage Code		Pressure	Pass-through	
		2G	5 ft (1.6m)		8	220-240 V AC, 50/60Hz, 1Ø			
Streamline® Compounding Isolator	SCI	2G	5 ft (1.6m)	C	Circular glove port (300 mm x 300 mm)	8	220-240 V AC, 50/60Hz, 1Ø	P0	Pro - 2 Pass - 3 + ≥
		3G	6 ft (1.95m)	O	Oval glove port (200 mm x 300 mm)	9	110-120 V AC, 50/60Hz, 1Ø	N1	Pro - 2 Pass - 3
								N2	Pro - 3 Pass - 2

Upon ordering, input material of construction at the end of the model code: SCI-2GC_-N1RL-1-SE-SS or -EG

- ▶ SS: Full stainless steel exterior
- ▶ EG: Electrogalvanized steel with ISOCIDE™ coating

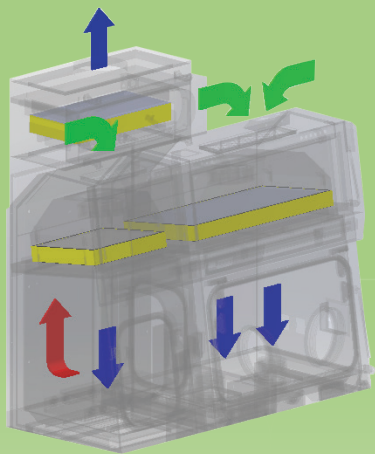

- HEPA-filtered air
- Room air / Ambient air
- Unfiltered / Potentially contaminated air

Total Exhaust

- Ambient air is pulled through the inlet pre and main filter via the main fans at the top of the isolator. This creates positive pressure on the plenum which provides the downflow of air with a velocity of 0.40 m/s ± 20%.
 - The pre-filter extends the life of the filters by trapping larger particulates that can easily clog the main filters.
- This downflow supply then provides an ISO Class 5 environment and unidirectional airflow inside the isolator; thus, protecting the materials inside the main chamber and pass-through.
- Air from the work zone and pass-through is then quickly purged by the fans to keep the area clean. The purge is completely exhausted through HEPA filters as well; ensuring that only clean air is exhausted back to the environment.

Isolator (SCI) models

11RL-1-SE

Pressure	Airflow Scheme		Pass-Through zone		Exhaust Type	Code	Sharps Provision	
	R	S	L	R				
Process zone: 37 Pa (min) Pass-through zone: 25 Pa (min)	R	Recirculating	L	1 Left	Double HEPA Exhaust (BIBO Top and non-BIBO Bottom)	1	Without	0
Process zone: 25 Pa (min) Pass-through zone: 37 Pa (min)	S	Single Pass	R	1 Right	Single Exhaust (Top, non-BIBO)	2	With (inside work zone) 8 qts: 171.45 x 254 x 285.75mm (6.75" x 10" x 11.25")	SI
Process zone: 37 Pa (min) Pass-through zone: 25 Pa (min)					Single Exhaust (Top, BIBO)	3	With (below work zone) 5 gal: 190.50 x 266.70 x 431.80mm (7.5" x 10.50" x 17.0")	SB
					With (beside work zone) 5 gal: 190.50 x 266.70 x 431.80mm (7.5" x 10.50" x 17.0")*		SE	

* The configuration allows for 1 sharps container and 1 stainless steel vessel for other laboratory waste.

GENERAL SPECIFICATIONS

Streamline® Compounding Isolator

		SCI-2G _ _	SCI-3G _ _
Main Chamber Nominal Size (Width)		1.6 meters (5')	1.95 meters (6')
External Dimension (W x D x H)	With sharps bin and exhaust collar	1903 x 845 x 2273 mm (74.9" x 33.3" x 89.5")	2208 x 845 x 2273 mm (86.9" x 33.3" x 89.5")
	With sharps bin and without exhaust collar	1903 x 845 x 1998 mm (74.9" x 33.3" x 78.7")	2208 x 845 x 1998 mm (86.9" x 33.3" x 78.7")
	Without sharps bin and with exhaust collar	1645 x 845 x 2273 mm (64.8" x 33.3" x 89.5")	1950 x 845 x 2273 mm (76.8" x 33.3" x 89.5")
	Without sharps bin and without exhaust collar	1645 x 845 x 1998 mm (64.8" x 33.3" x 78.7")	1950 x 845 x 1998 mm (76.8" x 33.3" x 78.7")
Main Chamber Work Zone Internal Dimension (W x D x H)		965 x 620 x 620 mm (38" x 24.4" x 24.4")	1270 x 620 x 620 mm (50" x 24.4" x 24.4")
Pass-through Internal Dimension (W x D x H)		433 x 620 x 620 (17" x 24.4" x 24.4")	433 x 620 x 620 (17" x 24.4" x 24.4")
Work Zone and Interchange Chamber Performance		ISO Class 3 (at rest), ISO Class 5 (in operation); Class 1, Federal Standard 209E	
Downflow and Exhaust Filter Type		H14 filters with integral metal guards and filter frame gaskets; fully compliant with EN 1822 (H14) and IEST-RP-CC001.3 requirements (each cabinet has individual downflow and exhaust filters)	
Typical Filter Efficiency		>99.999% for particle size 0.3 micron	
Airflow Volume	Required Exhaust With Optional Hard Ducting	Contact Esco for more information.	190m ³ / h (112 cfm)
	Static Pressure For Optional Hard Ducting	Contact Esco for more information.	27 Pa / 0.10 in H ₂ O
LED Light Intensity		≥ 800 lux	
Isolator Construction	Main Body EG Steel	1.5 mm (0.06") 16 Gauge Electro-Galvanized Steel with White Oven-Baked Epoxy-Polyester ISOCIDE™ Antimicrobial Powder Coated Finish	
	Main Body Stainless Steel	1.5 mm (0.06") 16 gauge stainless steel, type 304, with 4B finish	
	Work Tray and Side Walls	1.5 mm (0.06") 16 gauge stainless steel, type 316L, with 4B finish	
Electrical	220-240 V AC, 50/60Hz, 1Ø	SCI-2G-	SCI-3G-
	Cabinet Power Amp	Contact Esco for more information.	10 A
	Cabinet Nominal Power	Contact Esco for more information.	362 W
	Cabinet BTU	Contact Esco for more information.	1235
	110-120V, AC, 60 Hz, 1Ø	SCI-2G-	SCI-3G-
	Cabinet Full Load Amps (FLA)	6A	9.5 A
	Optional Outlets FLA	Contact Esco for more information.	5 A
	Cabinet Nominal Power	Contact Esco for more information.	362 W
	Cabinet BTU	Contact Esco for more information.	1236
Net Weight		Contact Esco for more information.	550 kg (1220 lbs)
Shipping Weight		392.5 kg (865 lbs)	620 kg (1370 lbs)
Shipping Dimensions, Maximum (W x D x H)		1600 x 990 x 2210 mm (62.6" x 39.0" x 87.0")	1600 x 990 x 2250 mm (86.7" x 37.8" x 88.6")
Shipping Volume, Maximum*		3.48 m ³ (122.9 cu.ft)	4.75 m ³ (167.7 cu. ft)
Optional Accessories	UV Lamp	5170543	5170543
	Carbon Filter	5170225	5170225
	Adjustable Hydraulic Stand	5131175	5131177
	CCTV Camera	5180034	5180034
	Rear View	5180033	5180033

Note: A 4-glove port (4G) design is possible by combining two units of 2-glove port (2G) isolators interconnected by a vertical non-interlock door; it has pass-through chambers on both sides.

All common surgical gloves can be attached to the cuff rings; thereby, making the system adaptable to operator preference.

ENGINEERING DRAWING

SCI Recirculating Model (SCI-3GC_-N1RL-1-SE)

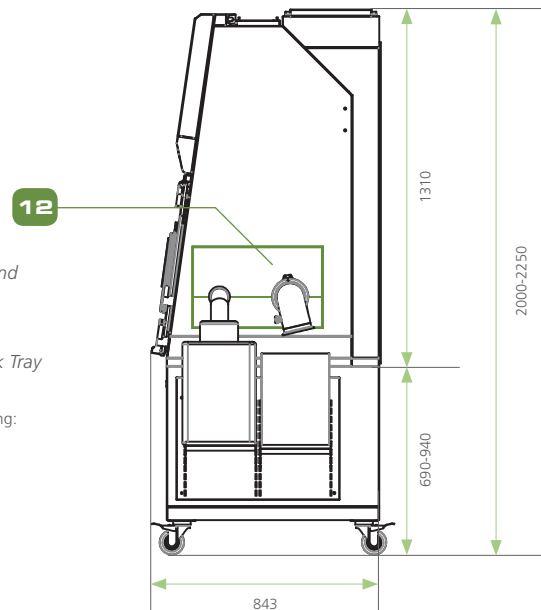
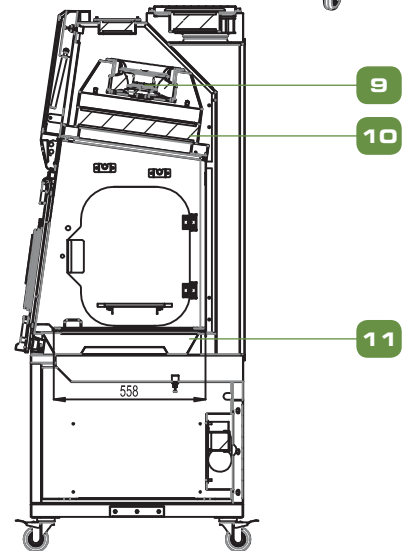
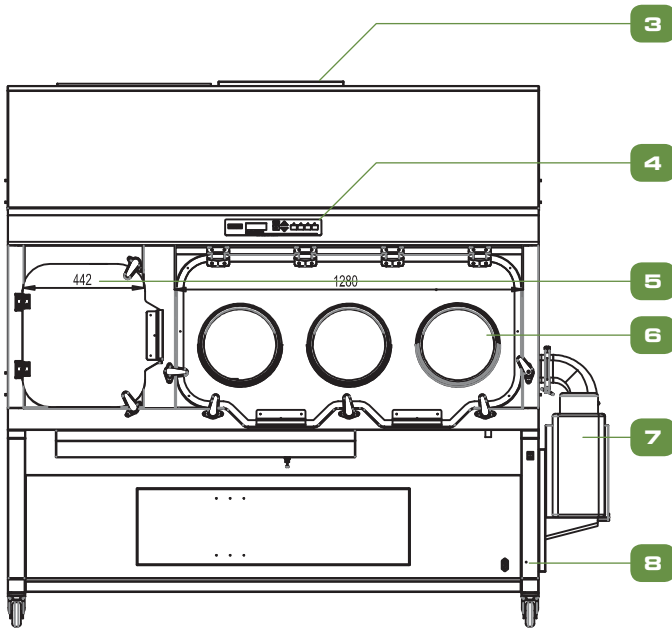
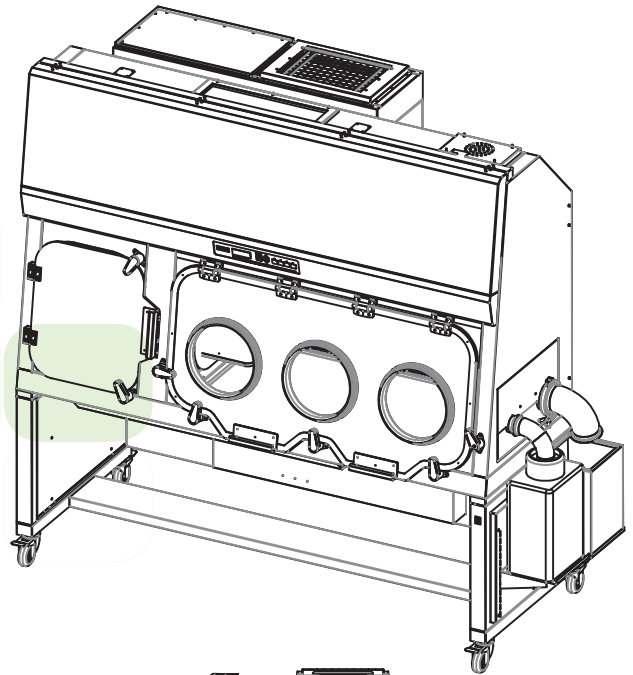
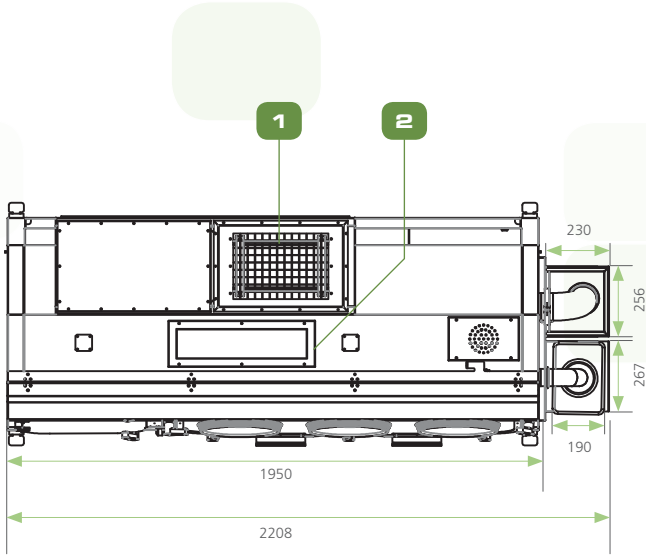

- 1. Exhaust H14 Filter
- 2. Air Intake H14 Filter
- 3. Exhaust Collar
- 4. Esco Sentinel™ Gold Microprocessor Controller
- 5. Pass-Through Hinged Outer Door
- 6. Circular Glove Ports
- 7. Sharps Disposal Container

- 8. Hydraulic-Height Adjustable Stand
- 9. Supply Fan
- 10. Supply H14 Filter
- 11. Single-Piece Stainless Steel Work Tray
- 12. Adaptor Plate

Note: Can cater to any of the following:

- sharps disposal (SE option)
- BioVap™ nozzle
- other retrofitted utilities/ accessories

ENGINEERING DRAWING

SCI Recirculating Model (SCI-2GC_-N1RL-1-SE)

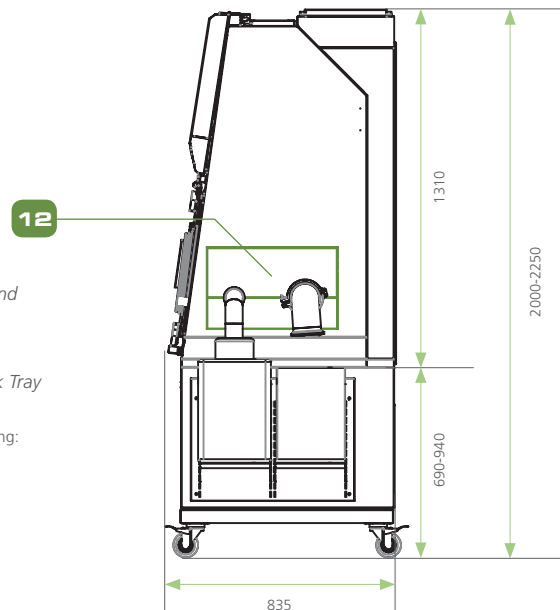
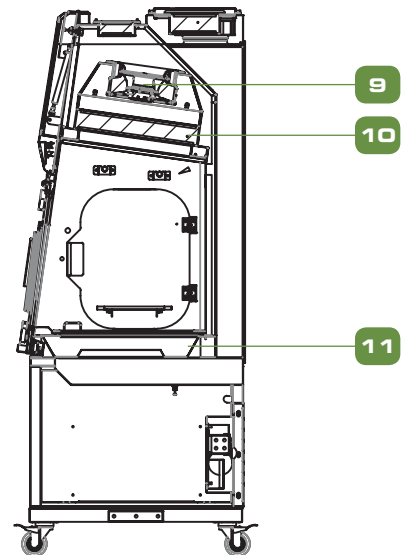
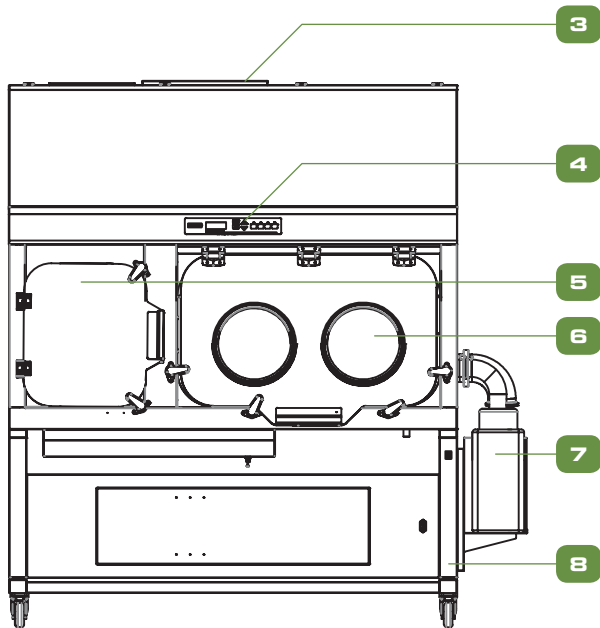
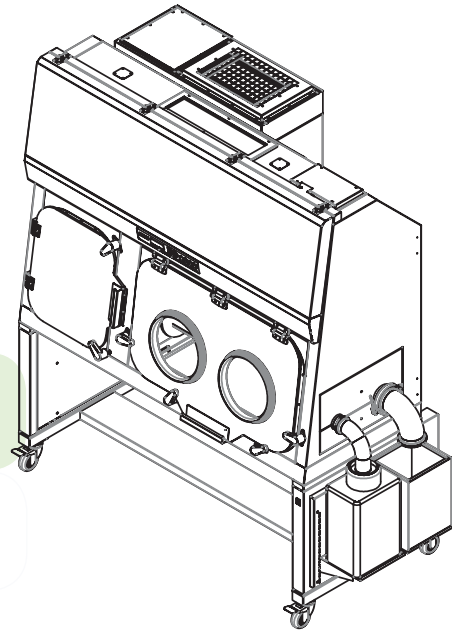
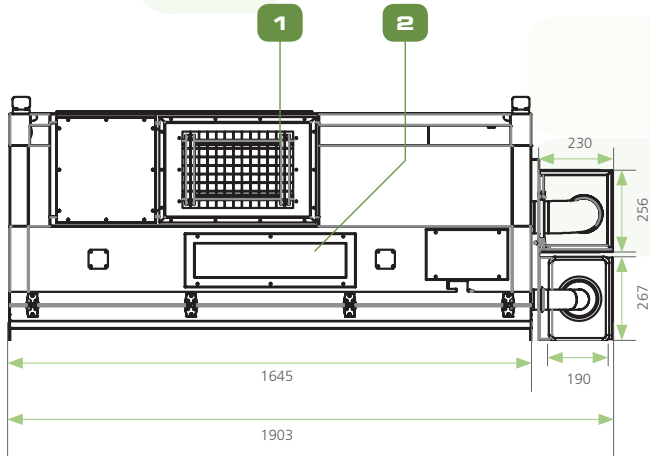

- | | |
|--|--|
| 1. Exhaust H14 Filter | 8. Hydraulic-Height Adjustable Stand |
| 2. Air Intake H14 Filter | 9. Supply Fan |
| 3. Exhaust Collar | 10. Supply H14 Filter |
| 4. Esco Sentinel™ Gold Microprocessor Controller | 11. Single-Piece Stainless Steel Work Tray |
| 5. Pass-Through Hinged Outer Door | 12. Adaptor Plate |
| 6. Circular Glove Ports | Note: Can cater to any of the following: |
| 7. Sharps Disposal Container | - sharps disposal (SE option) |
| | - BioVap™ nozzle |
| | - other retrofitted utilities/ accessories |

10

ENGINEERING DRAWING

SCI Total Exhaust Model (SCI-3GC_N1SL-1-SE)

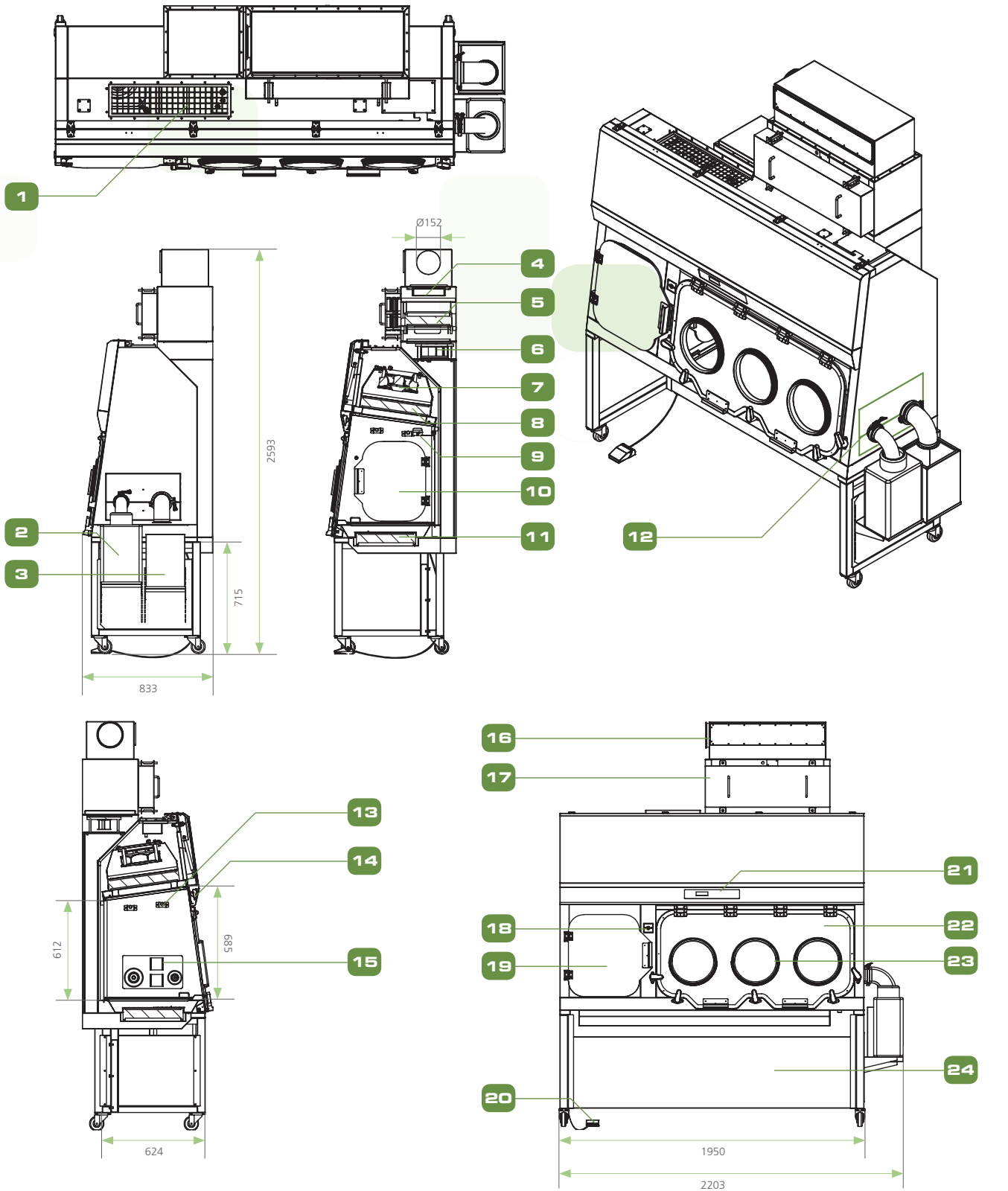

- | | | | |
|--|------------------------------|------------------------------------|---------------------------------------|
| 1. Air Inlet Pre-Filter | 8. Supply H14 Filter | 13. IV Bar (Optional) | 20. Footswitch For Inner Door |
| 2. Sharp Container (Optional) | 9. Airflow Sensor | 14. Lighting | 21. Esco Sentinel Control |
| 3. Stainless Steel Waste Bin (Optional) | 10. Pass Chamber Inner Door | 15. Electrical Outlet (Optional) | 22. Round Glove Ports Ø300mm |
| 4. Carbon Filter (Optional) | 11. First Exhaust H14 Filter | 16. Exhaust Collar | 23. Main Chamber Polycarbonate Window |
| 5. Exhaust H14 Filter, Bag-In Bag-Out (BIBO) | 12. Adaptor Plate | 17. BIBO Filter Access Cover | 24. Support Stand SPC-6A0 (Optional) |
| 6. Exhaust Fan | | 18. Pass Chamber Outer Door | |
| 7. Supply Fan | | 19. Pass Chamber Outer Door Switch | |

Note: Can cater to any of the following:

- sharps disposal (SE option)
- BioVap™ nozzle
- other retrofitted utilities/ accessories

Isolation Technology

Isolation containment systems provide inherently superior sterility compared to open front clean air devices such as laminar flow clean benches and Class II biological safety cabinets. USP <797> guidelines specify that isolators may be situated in an area subject to less severe environmental controls compared with open front clean air devices.

Isolators are an effective solution especially for lower-volume pharmaceutical processes. They reduce operating and renovation costs, take up less space, and are easier to maintain.

Positive pressure isolators are designed for non-hazardous aseptic processes, while negative pressure isolators are intended to promote personnel and environment safety during processing of hazardous materials such as antineoplastic or cytotoxic compounds.

- For volatile hazardous drugs, it is recommended to have a negatively pressured, total exhaust isolator. Alternatively, a recirculating isolator with optional exhaust activated carbon filter and/or external ventilation, can be selected.

Maximum Patient Protection and Product Sterility

The combination of downflow and exhaust HEPA filters provides the Esco Streamline® Compounding Isolator, a fully integrated envelope for product and operator protection in all configurations.

- Advanced mini-pleated supply HEPA filters are tested to >99.999% efficiency for to 0.3 micron particulates; significantly better than conventional filters.
 - An improved mini-pleat separation technique maximizes filter surface area, improves efficiency and extends filter life over conventional separation.
 - The HEPA supply filter provides an ISO Class 5 air in the work

surface via a gentle vertical laminar flow.

- All filters have sampling ports for maintenance services.

Mini-pleat Separatorless Filter (left) vs. Conventional Aluminum Separator Filter (right)

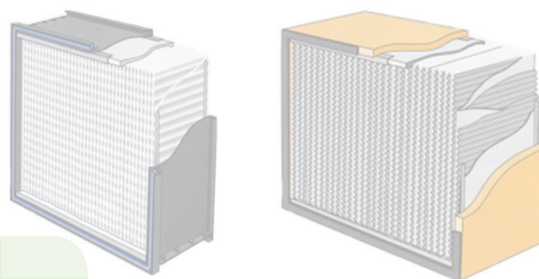

Esco cabinets use Swedish Camfil Farr® mini-pleat filters without aluminum separators to increase filter efficiency, minimize the chance of leakage, and prolong filter life. Filters include a lightweight aluminum frame for structural stability and elimination of swelling common to conventional wood frames.

- Laminar airflow within the work zone and pass-through enables recovery of chamber atmosphere to ISO Class 5 conditions within 3 minutes following a worst-case contamination event. The entire work zone air is changed 20-30 times per minute.
 - Refer to separate information on recovery testing carried out by Esco.
- Optional sharps disposal system enables a smoother work flow while minimizing material transfer to enhance patient protection and product sterility.
 - The interface between sharps disposal bin and isolator is aerosol tight to avoid ingress of contamination during the disposal operation.
- Safe-change cuff rings enable glove change with zero risk of contamination.
- The exterior construction of an isolator can either be of full stainless steel or electrogalvanized steel with an ISOCIDE™ antimicrobial powder coating to minimize contamination.
 - Performance results are available upon request.

Esco Filter Efficiency

(%) Typical Penetration

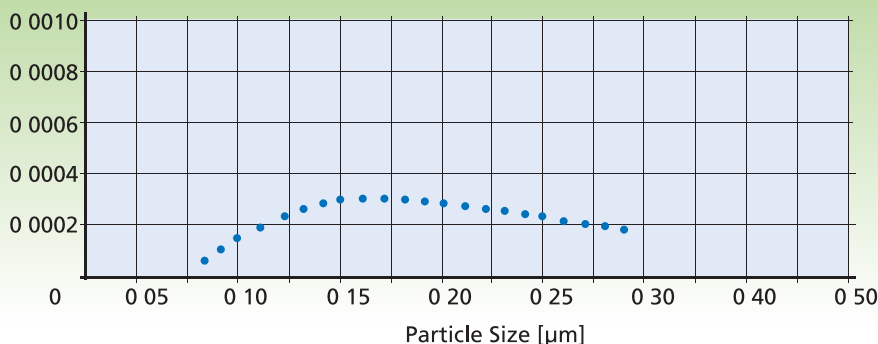

● Typical Penetration

The SCI unit uses ULPA filters (as per IEST-RP-CC001.3 and HEPA (H14) filter as per EN 1822) with a typical efficiency of >99.999% at 0.1 to 0.3 microns, providing ISO Class 5 air cleanliness as per ISO 14644-1.

Fan Efficiency

The Streamline® Compounding Isolator fan system is designed for maximum energy efficiency with minimal maintenance.

- Designed with a centrifugal, direct-drive, and external rotor motors to reduce operating costs.
- Unique Esco motor/fan orientations minimize noise and vibration.
- Built-in solid-state variable speed controllers are infinitely adjustable from Off to Maximum



Electrical Outlets and Utility Fittings

- Electrical outlet, ground fault, North America
- UV lamp
- IV bar with hooks
- Cleaning accessories
- Cord pass-through (NSF standard)
- Alarm package
- Thimble exhaust collar
- Duplex and/or GFI outlet
- Perforated shelf to increase work zone space
- Storage Bin
- Side Exhaust Connection (for TE units)
- Back-up battery for electromagnetic interlocking doors (Contact Esco for more information)
- Side syringe pass-through chamber

Highlights

- Output 10 VDC, max. 1.1 mA, Tach output, Control input 0-10 VDC.PWM
- Motor current limit, soft start, locked-rotor protection, over temperature protected electronics/motor
- Condensate discharge holes: none, open rotor
- Ingress protection of IP54
 - Material: Fiberglass reinforced composite
 - Impeller: PA6
 - Direction of rotation: Clockwise, seen on rotor

ISOCIDE™ Antimicrobial Powder-Coating

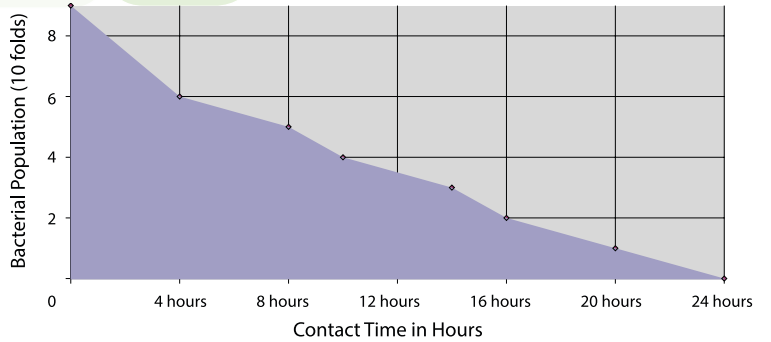

All exterior painted surfaces are powder-coated with Esco ISOCIDE™, an antimicrobial inhibitor to minimize contamination. Performance results are available upon request. Contact Esco or your Esco Sales Representative for details.

Sentinel™ Microprocessor Control, Monitoring System

The Esco Sentinel™ microprocessor-based control system supervises operation of all cabinet functions. Controls are configurable to meet user requirements.

Enlarged, multi-line digital read-out with alpha-numeric display indicates all input, status and alarm functions.

Work zone, interchange pressures and downflow velocity are continuously measured and displayed. Integrated true airflow sensor is temperature compensated for improved accuracy.

Password-protected administration can be set to restrict access to main menu.

Color coded indicator lamps display green for fan operation; blue for LED lights and electrical outlet; and orange for AUX function ON.

Optional audible and visual alarms warn of unsafe conditions such as low chamber pressure.

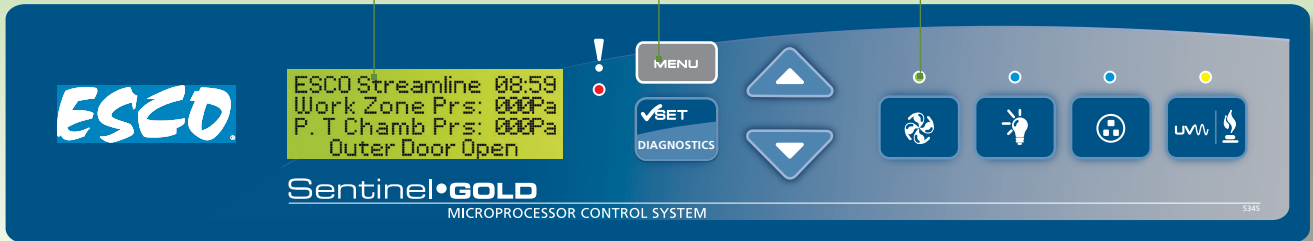

Sentinel Microprocessor Control System, Programmable

■ When programmed ON

- the start-up sequence confirms status with Air Safe and local time display.
- the Personal Identification Number (PIN) access restricts unauthorized adjustments.

Main Control Panel Features

- Work zone and pass-through pressures are monitored and displayed on the LCD screen
- Continuous monitoring and display of cabinet laminar airflow on large, easy-to-read LCD display.
- An optional alarm package (pressure and airflow) is available for users with more sophisticated requirements.

SAFE GLOVE CHANGE PROCEDURE: REPLACING DISPOSABLE GLOVES

.Safe change design system allows glove change at the middle of a process or when the equipment is in operation



1 Pull the glove / sleeve outside the isolator work zone. Check the material integrity of the two items.



2 Fold the fingers of the gloves and move it towards the isolator's work zone to ensure containment during replacement procedures.



3 Remove the outer O-ring from the cuff rings. This elastic ring is used to seal the gloves and sleeves together; preventing operator exposure.



4 Remove the second O-ring towards the sleeves to easily remove the gloves at a later stage.



5 Carefully roll the open end of the old glove from the middle groove to the outer groove of the cuff rings. Do not completely remove the glove to prevent exposure risk.



6 Take the new glove and attach it to the last groove of the cuff ring. Ensure that the thumb is positioned at the top.



7 Install the O-ring nearest the sleeves over the new gloves. This will tightly fasten the new gloves to the cuff rings while removing the old one.



8 Verify that the thumb of the new glove is positioned on top. Afterwards, carefully loosen the old glove from the outer groove.



9 Place the other O-ring back and position it on the outer groove of the cuff ring. This will fasten the new gloves with the sleeves.



10 Put back the glove and sleeve into the work zone of the isolator to properly discard the used glove without contaminating the outside environment.



11 Working with the adjacent gloved hand, carefully remove the old glove and properly dispose of it inside the isolator.



12 The procedure is now complete. Strict compliance to the process guarantees prevention from exposure to hazardous substances.



SAFE GLOVE CHANGE PROCEDURE: REPLACING THE SLEEVES



1 Roll the entire glove and sleeve into the isolator work zone. Afterwards, remove the O-ring attaching the sleeves to the glove port.



2 Carefully roll the open end of the old sleeves from the inner groove to the outer groove of the port. Ensure strict adherence to prevent breach in the isolation technology.



3 Take the new sleeves and ensure that the thumb is positioned at the top. This step guarantees easy usage when the operator enters his/her hand in the isolator system.



4 Attach the new sleeves to the isolator port and position its open end on the inner-most groove. Ensure that the old sleeve will not be removed during this process.



5 Check that the thumb of the glove is positioned on top. Afterwards, carefully remove the old sleeve from the outer groove towards the inside of the isolator work zone.

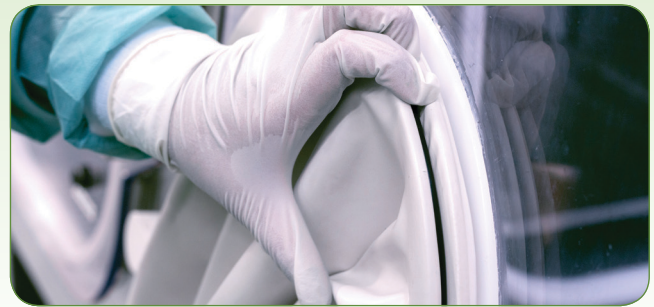

6 Re-attach the O-rings of the sleeves to the inner groove of the port. This will guarantee that the new sleeve is tightly attached to the port without any risk of operator occupational exposure.



7 Lastly, with the confirmation that the thumb of the newly attached sleeve is at the top, properly dispose the old sleeve through the isolator work zone. The procedure is now complete.



ESCO GLOBAL NETWORK

42 Locations In 21 Countries All Over The World

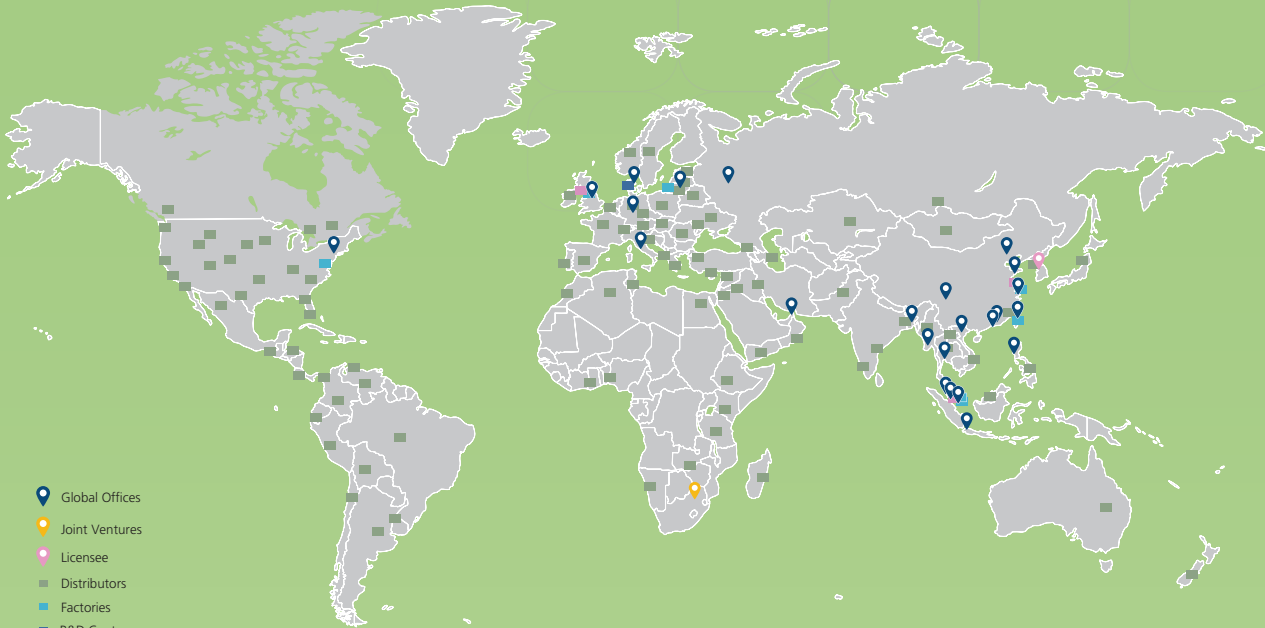

- Air Shower
- Aseptic Containment Isolator (ACTI)
- Ceiling Laminar Airflow Units
- Cleanroom Transfer Hatch
- Containment Barrier Isolator (CBI)
- Downflow Booth (DFB)
- Dynamic Floor Label Hatch
- Dynamic Pass Box
- Evidence Drying Cabinet
- Garment Storage Cabinet
- General Processing Platform Isolator (GPPI)
- Laminar Flow Horizontal Trolley
- Laminar Flow Straddle Units, Single and Double
- Laminar Flow Vertical Trolley
- Pass Box
- Soft Wall Cleanroom
- Sputum Booth
- Ventilated Balance Enclosure (VBE)
- Weighing and Dispensing Containment Isolator (WDCI)

Since 1978, Esco has emerged as a leader in the development of controlled environment, laboratory and pharmaceutical equipment solutions. Products sold in more than 100 countries include biological safety cabinets, fume hoods, ductless fume hoods, laminar flow clean benches, animal containment workstations, cytotoxic cabinets, hospital pharmacy isolators, and PCR cabinets and instrumentation. With the most extensive product line in the industry, Esco has passed more tests, in more languages, for more certifications, throughout more countries than any biosafety cabinet manufacturer in the world. Esco remains dedicated to delivering innovative solutions for the clinical, life science, research and industrial laboratory community. www.escoglobal.com.



Esco Pharma Pte Ltd
 21 Changi South Street 1 Singapore 486777 • Tel: +65 65420833
 Fax: +65 65426920 • Email: csis.pharma@escoglobal.com

Esco Technologies, Inc.
 2512 Metropolitan Drive, Suite 120 B
 Feasterville- Trevose, PA 19053-6738
 Tel: 215 322 2155 • Email: eti.pharma@escoglobal.com

Esco Gb Ltd
 Unit 2 R-evolution @ Gateway 36, Kestrel Way, Barnsley, S70 5SZ
 Tel: +44 (0) 1226 360 799 • Email: egb.pharma@escoglobal.com

Esco Global Offices: Bangladesh | Cameroon | China | Denmark | Germany | Hong Kong | Indonesia | Italy | Lithuania | Malaysia | Myanmar | Philippines | Russia | Singapore | South Africa | South Korea | Taiwan | Thailand | UAE | UK | USA | Vietnam



SCI Register, A4, UE, 01232020
 Esco can accept no responsibility for possible errors in catalogues, brochures and other printed materials.
 Esco reserves the right to alter its products and specifications without notice. All trademarks and logos in
 this material are the property of Esco and the respective companies.